

*Échelon*<sup>™</sup>

WINE  
CAPTAIN<sup>®</sup>  
MODELS

U  
S  
E  
R  
M  
A  
N  
U  
A  
L



**U-LINE**  
CORPORATION

## U-LINE CORPORATION LIMITED WARRANTY

U-Line Corporation warrants each U-Line product to be free from defects in materials and workmanship for a period of one year from the date of purchase; and warrants the sealed system (consisting of the compressor, the condenser, the evaporator, the hot gas bypass valve, the dryer and the connecting tubing) in each U-Line product to be free from defects in materials and workmanship for a period of five years from the date of purchase. During the initial one-year warranty period for all U-Line products U-Line shall: (1) at U-Line's option, repair any product or replace any part of a product that breaches this warranty; and (2) for all Marine, RV and Domestic U-Line products sold and serviced in the United States (including Alaska and Hawaii)and Canada, U-Line shall cover the labor costs incurred in connection with the replacement of any defective part. During years two through five of the warranty period for the sealed system, U-Line shall: (1) repair or replace any part of the sealed system that breaches this warranty; and (2) for all Marine, RV and Domestic U-Line products sold and serviced in the United States (including Alaska and Hawaii)and Canada, U-Line shall cover the labor costs incurred in connection with the replacement of any defective part of the sealed system. All other charges, including transportation charges for replacements under this warranty and labor costs not specifically covered by this warranty, shall be borne by you. This warranty is extended only to the original purchaser of the U-Line product. The Registration Card included with the product should be promptly completed by you and mailed back to U-Line or you can register on-line at [www.U-LineService.com](http://www.U-LineService.com).

The following are excluded from this limited warranty: installation charges; damages caused by disasters or acts of God, such as fire, floods, wind and lightning; damages incurred or resulting from shipping, improper installation, unauthorized modification, or misuse/abuse of the product; customer education calls; food loss/spoilage; door and water level adjustments (except during the first 90 days from the date of purchase); defrosting the product; adjusting the controls; door reversal; or cleaning the condenser.

If a product defect is discovered during the applicable warranty period, you must promptly notify either the dealer from whom you purchased the product or U-Line at P.O. Box 23220, Milwaukee, Wisconsin 53223 or at 414-354-0300. In no event shall such notification be received later than 30 days after the expiration of the applicable warranty period. U-Line may require that defective parts be returned, at your expense, to U-Line's factory in Milwaukee, Wisconsin, for inspection. Any action by you for breach of warranty must be commenced within one year after the expiration of the applicable warranty period.

**This limited warranty is in lieu of any other warranty, express or implied, including, but not limited to any implied warranty of merchantability or fitness for a particular purpose; provided however, that to the extent required by law, implied warranties are included but do not extend beyond the duration of the express warranty first set forth above. U-Line's sole liability and your exclusive remedy under this warranty is set forth in the initial paragraph above. U-Line shall have no liability whatsoever for any incidental, consequential or special damages arising from the sale, use or installation of the product or from any other cause whatsoever, whether based on warranty (express or implied) or otherwise based on contract, tort or any other theory of liability.**

Some states do not allow limitations on how long an implied warranty lasts or the exclusion or limitation of incidental or consequential damages, so the above limitations may not apply to you. This warranty gives you specific legal rights, and you may also have other rights which vary from state to state.

## INTRODUCTION

Congratulations on your purchase of U-Line ice making or refrigeration products. A pioneer in the field for more than 40 years, U-Line is the world's number one manufacturer of built-in, under-counter ice making and specialty refrigeration products. U-Line dedicates 100% of its research and development to these products. The result: U-Line technology leads the market with innovation, design, depth of product line and performance.

U-Line also backs customers with a strong dealer network. U-Line's commitment to quality even extends to environmentally safe packaging. U-Line products are making life more convenient in homes, businesses, and hotels around the world.

### IMPORTANT

**PLEASE READ all instructions completely before attempting to install or operate the unit.**

Once you have your unit installed, we suggest you keep this manual in a safe place for future reference. Should any problems occur, refer to the **TROUBLESHOOTING** section of this manual. This information will help you quickly identify a problem and get it remedied. In the event you require assistance, please contact the dealer where you purchased your unit.

### PLEASE RECORD YOUR MODEL'S INFORMATION

Whenever you call to request information or service, you will need to know your model number and serial number. You can find this information on the serial plate located on the inside wall of your unit and on the warranty registration card.

### WARRANTY REGISTRATION CARD

The package containing this manual also includes your warranty registration information. Warranty coverage begins at the time your Wine Captain® model was purchased.

### NOTE

**Complete and mail the Warranty Registration Card as soon as possible to validate the registration date. You may also register the product online at [www.U-LineService.com](http://www.U-LineService.com).**

# User's Manual

---

---

If you do not return your Warranty Registration Card, U-Line will use the date of sale to the U-Line distributor as the first date of warranty for your new Wine Captain® model. Please also record the purchase date of your U-Line unit and your dealer's name, address and telephone number.

Model Number: \_\_\_\_\_  
Serial Number: \_\_\_\_\_  
Purchase Date: \_\_\_\_\_  
Dealer Name: \_\_\_\_\_  
Dealer Address: \_\_\_\_\_  
Dealer Telephone: \_\_\_\_\_

Keep this manual and the sales receipt together in a safe place for further reference.

## TABLE OF CONTENTS

WINE SELECTION SUGGESTIONS.....	3
SUGGESTIONS FOR MATCHING FOOD AND WINE .....	4
COMMON FOOD AND WINE MATCHES.....	4
GUIDE TO COMMON STYLES OF WINES .....	5
COMMON TASTING TERMS .....	6
SAFETY PRECAUTIONS .....	7
INSTALLATION .....	9
LEVELING THE UNIT .....	13
REVERSING THE DOOR .....	13
DOOR ADJUSTMENT .....	16
BUILT-IN INSTALLATION.....	18
OPERATION .....	18
INITIAL START-UP .....	19
ADJUSTING THE TEMPERATURE CONTROL.....	20
MAINTENANCE.....	22
TROUBLESHOOTING .....	26
TROUBLESHOOTING GUIDE .....	27

## WINE SELECTION SUGGESTIONS

Selecting the right wine for the right occasion can sometimes be a seemingly awkward or difficult task for the beginning wine enthusiast. We would therefore like to present you with a few suggestions which may provide a little more confidence and enjoyment when choosing and serving your wines.



When selecting wines, keep an open mind and do not be afraid to be adventurous. Do not view the subject of wine so seriously it discourages you from learning and discovering for fear of embarrassment if something is incorrect. Wine is best viewed as a hobby and enjoyed.

When assembling your collection, try not to become obsessed with "Vintages." Although a chart can provide itself as a useful tool, generalizations about a specific year have led more than one collector to disappointment. In many instances an "off year" will provide a better value and more near term drinking enjoyment.

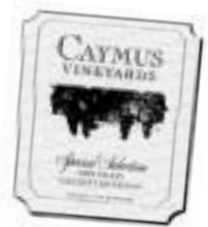

The primary guideline to the subject of wine you need to follow is your own palate. Do not be afraid to make mistakes. Experiment, discover, but most of all, enjoy yourself and your new Wine Captain® model.



# User's Manual

---

---

## SUGGESTIONS FOR MATCHING FOOD AND WINE

Although there are no hard fast rules for matching wine to food, some guidelines should be observed. Delicate dishes should be accompanied by lighter more delicate wines. Full flavored foods should be matched with fuller bodied wines.

As a general rule one should aim to ascend in flavor and quality of wines served.

**A DRY WINE Before A SWEET WINE**  
**A WHITE WINE Before A RED WINE**  
**A YOUNG WINE Before An OLD WINE**  
**A LIGHT-BODIED WINE Before A FULL-BODIED WINE**

Any step back in quality will be noticed. If a fine wine were to be tasted prior to a lesser wine, many of the fine wine's subtle qualities may be missed.

## COMMON FOOD AND WINE MATCHES

### **Fish, Shell Fish, Crab, Oysters**

Dry White Wines, Light Sparkling or Extra Dry Champagne

### **Beef, Venison**

Full Bodied Red Wines

### **Pork, Veal, Lamb & Poultry**

Light Bodied Red Wines

### **Fruit**

Sweet White and Sparkling Wines



# GUIDE TO COMMON STYLES OF WINES

## Red Wines

Full-Bodied Dry:	(California)	Zinfandel, Cabernet
	(French)	Rhone, Chateauneuf-du-Pape
	(Italian)	Barbaresco, Barolo
Medium-Bodied Dry:	(California)	Pinot Noir
	(French)	Bordeaux, Burgundy
Light-Bodied Dry:	(French)	Beaujolais
	(Italian)	Chianti, Bardolino

## White Wines

Full-Bodied Dry:	(California)	Chardonnay
	(French)	Montrachet, Meursault Puligny-Montrachet
Medium-Bodied Dry:	(California)	Sauvignon Blanc
	(French)	Pouilly-Fuisse, Sancerre Vouvray, Graves
Light-Bodied Dry:	(French)	Chablis, Muscadet Pouilly-Fume
Full-Bodied Very Sweet:	(Germany)	Beerenauslese
	(French)	Sauternes
	(Hungary)	Tokay
Medium-Bodied Semi-Sweet:	(California)	Gewurtztraminer
	(Germany)	Liebfraumilch
Light-Bodied Off Dry:	(Germany)	Rhine, Mosel, Riesling

## COMMON TASTING TERMS

- Acidity:** A critical element of wine, preserves the wine's freshness. In excess results in an overly tart and sour wine.
- Balance:** A desired trait where tannin, fruit and acidity are in total harmony. Wines with good balance tend to age gracefully.
- Body:** The weight and presence of wine in the mouth provided by the alcohol and tannin level. Full-bodied wines tend to have this strong concentration.
- Bouquet:** The blending of a wine's aroma within the bottle over a period of time. Caused by volatile acidity.
- Complex:** A subjective term often used in tasting. A wine is said to be complex if it offers a variety of flavors and scents that continue to evolve as it develops.
- Flabby:** A wine that lacks structure, or is heavy to the taste, lacks acidity.
- Full-Bodied:** Wine high in alcohol and extract, generally speaking fills the mouth, powerful.
- Lean:** Generally wines that are slim, lacking of generosity or thin.
- Oaky:** A desirable flavor imparted to wine if done in moderation. Most wines are aged in oak barrels one to three years, thereby receiving this toasty oak characteristic. However, if a weak wine is left in contact too long with an oak barrel it will tend to be overpowered with an oaky taste.
- Tannin:** Tannins are extracted from the grape skins and stems and are necessary for a well balanced red wine. Tannins are easily identified in wine tasting as the drying sensation over the gums. Tannins generally fade as a wine ages.

# SAFETY PRECAUTIONS

Do not attempt to install or operate your unit until you have read the safety precautions in this section. Safety items throughout this manual are labeled with a Danger, Warning or Caution based on the risk type.

## DEFINITIONS



This is the safety alert symbol. It is used to alert you to potential personal injury hazards. Obey all safety messages that follow this symbol to avoid possible injury or death.



### **DANGER**



**DANGER** indicates an imminently hazardous situation which, if not avoided, will result in death or serious injury.



### **WARNING**

**WARNING** indicates a potentially hazardous situation which, if not avoided, could result in death or serious injury.



### **CAUTION**

**CAUTION** indicates a potentially hazardous situation which, if not avoided, may result in minor or moderate injury.

### **CAUTION**

**CAUTION** used without the safety alert symbol indicates a potentially hazardous situation which, if not avoided, may result in property damage.

### **IMPORTANT**

Indicates installation, operation or maintenance information which is important but not hazard related.

# User's Manual

---

---

## GENERAL PRECAUTIONS



### **DANGER**



**RISK OF CHILD ENTRAPMENT.** Before you discard your Wine Captain, remove the door and leave shelves in place so that children may not easily climb inside.



### **WARNING**

- Never attempt to repair or perform maintenance on the unit until the electricity has been disconnected.
- Altering, cutting of power cord, removal of power cord, removal of power plug, or direct wiring can cause serious injury, fire and/or loss of property and/or life and will void the warranty.

### **CAUTION**

- Do not lift unit by door handle.
- Use care when moving the unit. Some edges are sharp and may cause personal injury. Wear gloves when moving or repositioning the unit.
- Never install the unit behind closed doors. Be sure front grille is free of obstruction. Obstructing free air flow can cause the unit to malfunction, and may void the warranty.
- Allow unit temperature to stabilize for 24 hours before use.
- Failure to clean the condenser every three months can cause the unit to malfunction. This could void the warranty. Use care when moving this unit. Some edges may be sharp and could cause personal injury. wear gloves when moving or repositioning the unit.

### **CAUTION**

- Use only genuine U-Line replacement parts. Imitation parts can damage the unit, and may void the warranty.

# INSTALLATION

Wine Captain® models are manufactured in two different sizes. The 2015WC will accommodate 24 (750 ML size) wine bottles and the 2075WC will accommodate 48 (750 ML size) wine bottles. Unless otherwise noted, all documentation pertains to both units.

## SITE PREPARATION

1. Position the unit on a flat, level surface, capable of supporting the entire weight of the unit. Remember the unit will be significantly heavier once it is fully loaded.
2. This unit requires a grounded and polarized 115 VAC, 60Hz, 15A circuit (normal household current).
3. Avoid connecting the unit to a Ground Fault Interruptor (GFI). GFIs are prone to nuisance tripping which will cause the unit to shut down. GFIs are generally not used on circuits with power equipment that must run unattended for long periods of time.
4. The unit must be installed according to your local codes and ordinances.



## **DANGER**



### **ELECTROCUTION HAZARD!**

**Electrical Grounding Required.** This appliance is equipped with a three prong (grounding) polarized plug for your protection against possible shock hazards. It must be plugged into a properly grounded three-prong receptacle

- **NEVER** remove the round grounding prong from the plug.
- **NEVER** use a two-prong grounding adapter.
- **NEVER** use an extension cord to connect power to the unit.

Where a two-prong wall receptacle is encountered or a longer power cord is required, contact a qualified electrician to have it replaced in accordance with applicable electrical codes.

# User's Manual

## NOTE

All U-Line units (except Stainless Steel models) have a zero clearance for the door to open (see Figure 1). See **BUILT-IN INSTALLATION** for additional clearance requirements. Stainless Steel models require a minimum of 2-1/2" door handle clearance when installed against a wall.

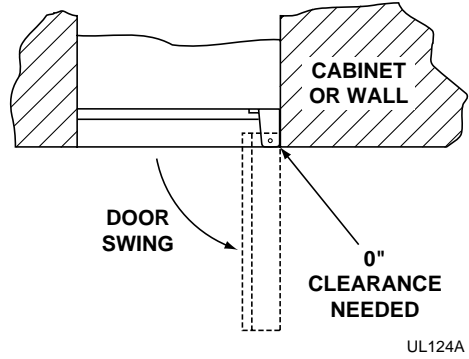

Figure 1

5. Position the unit to allow free air flow through the front grille (see Figure 2).

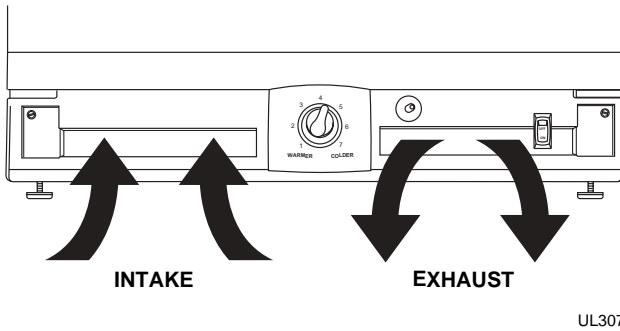

Figure 2

6. Wipe out inside of unit with a damp cloth.
7. Final finish of the wooden wine rack trim must be applied at least 24 hours before re-installing the wooden rack trim into the cabinet.
8. Be sure to install the Anti-Tip brackets. Follow the instructions provided with the Anti-Tip bracket kit.

## WOOD TRIM ON WINE RACKS

Your U-Line Wine Captain® Model is equipped with a natural wood trim on the wine racks for appearance and durability. The wood trim has been coated at the factory with a clear vinyl sealer, which will adequately protect the wood in normal usage.



### WARNING

To prevent permanent damage to the inner liner of your Wine Captain®, the wine rack wood trim **MUST** be removed from the unit for staining and/or finishing. Allow stain/finish to dry thoroughly (at least 24 hours per coat) in accordance with the stain/finish manufacturer's instructions prior to re-installing the wood trim inside the cabinet of the Wine Captain®. Failure to do so may cause the inner liner of the unit to have a permanent odor, which is not covered by the warranty.

You have 3 options regarding the wood trim on the wine racks. (1) You can leave as is, (2) add a final finish coat or (3) you may stain the wood trim. The final finish coat was not applied at the factory so that the wood trim could be stained. **YOU CANNOT STAIN THE WOOD TRIM ONCE YOU APPLY THE FINAL FINISH.** Review the following guidelines when staining and or sealing the wood to ensure proper adhesion and durability of the finish.

#### To add a final finish coat:

1. Remove five racks with wood trim from unit, see **RACK REMOVAL/INSTALLATION**.
2. Remove screws securing wood trim to racks.
3. Lightly scuff sand the molding with 280 grit 3M™ Tri-M-Ite™ sand-paper.
4. Remove sanding dust with a clean, dry cloth.
5. Apply a thin coat of a clear protective finish; the factory-applied seal is compatible with virtually all finishes. A low odor, water clean up, quick drying finish such as Minwax® Polycrylic® Protective Finish is recommended. Follow container label for directions.
6. Lightly sand and reapply if desired.

# User's Manual

---

---

## To stain for a different wood color:

1. Remove five racks with wood trim from unit, see **RACK REMOVAL/INSTALLATION**.
2. Remove screws securing wood trim to racks.
3. Apply Minwax® Water-Based Wood Stain to wood with a synthetic foam brush. Stain must penetrate approximately 3 minutes. After this period, while stain is still wet, take a stain dampened rag and remove all excess stain. Wipe in the direction of the grain with medium pressure to achieve the desired stain color.
4. After 2 hours, repeat step 3. This will even out the color of the wood.
5. Allow stain to dry for a minimum of 3 hours before finishing.
6. If desired sand the wood with very fine sandpaper to smooth the surface from the staining process.
7. Remove all dust from the wood. Apply one coat of Minwax® Ultra Polycrylic® Protective Finish with a synthetic bristle brush to the wood. This finish should be applied in a thin coat following the direction of the grain. First apply the finish to the back and sides of the wood. Allow this to dry for two hours. Next apply the finish to the front side of the wood and allow to dry for two hours. Sand with very fine sandpaper (220 grit). Reapply in the same manner 3 times total. After the third coat do not sand the surface.
8. Allow the final coat to dry for 24 hours before installing the wood to the Wine Captain® racks.

MinWax® Polycrylic® is an ultra fast-drying water-based finish.

## LEVELING THE UNIT

Position the unit on a flat, level surface, capable of supporting the entire weight of the unit when full.

This unit contains four adjustable leveling legs. Turn the legs clockwise to raise and counterclockwise to lower (see Figures 3 & 4).

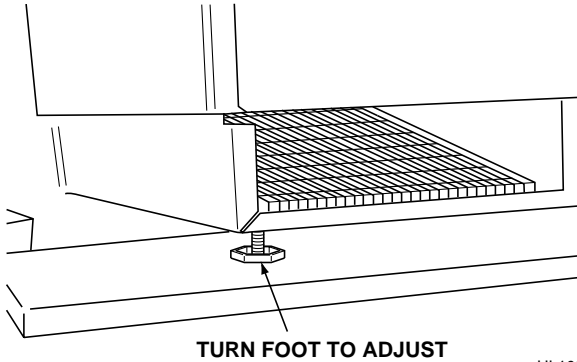

TURN FOOT TO ADJUST

UL105

Figure 3

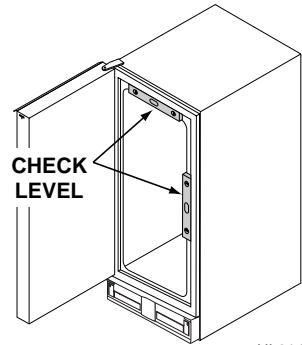

CHECK LEVEL

UL314

Figure 4

## REVERSING THE DOOR

All Wine Captain® models (except Stainless Steel models which must be ordered left or right hand opening) are field reversible for left or right hand opening. The door opening is easily reversed by moving the hinge hardware to the opposite side (see Figure 5).

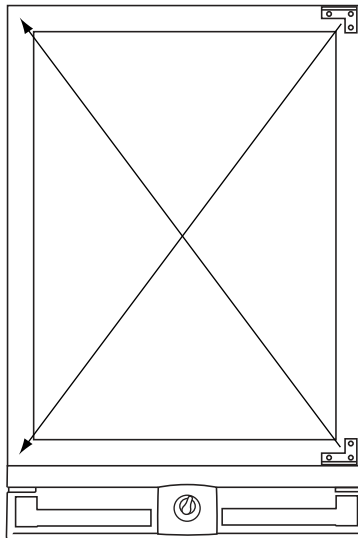

UL318

Figure 5

# User's Manual

To reverse the door:

1. Remove top hinge screw pin (7/64" Allen wrench) from cabinet (see Figure 6). Remove door by tilting forward and lifting off bottom hinge pin.

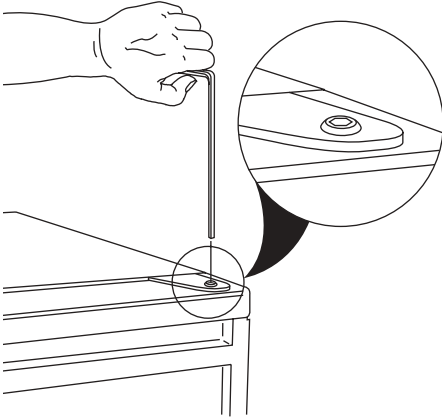

UL310

Figure 6

2. Remove plastic screw plugs (3 each, top and bottom) from new hinge location. Do not discard (see Figure 7).

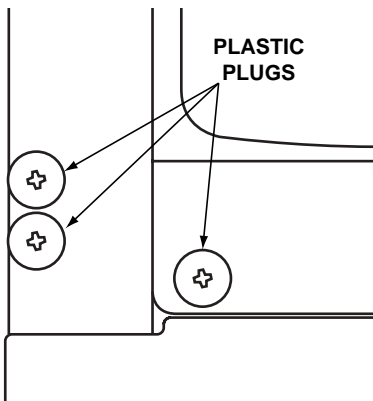

UL308

Figure 7

3. Remove top hinge (3 screws), reinstall hinge screw pin, and remount on opposite side BOTTOM (see Figure 8).

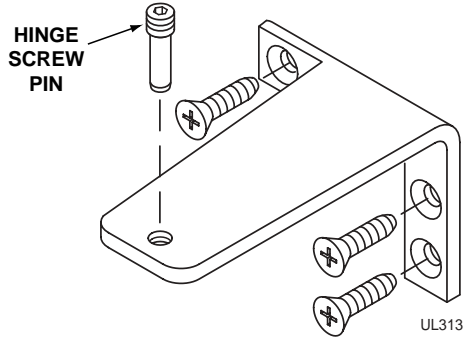

Figure 8

4. Remove the two door closer plastic inserts from the existing bottom hinge and install as shown on the new bottom hinge (see Figure 9).

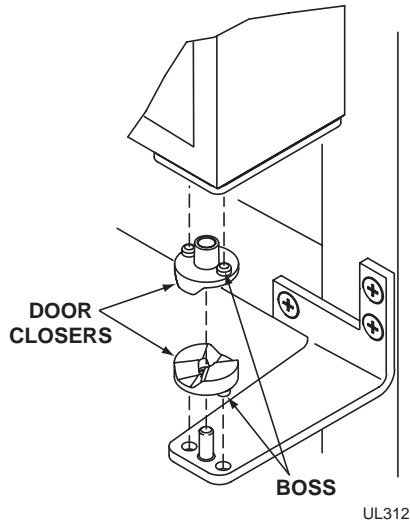
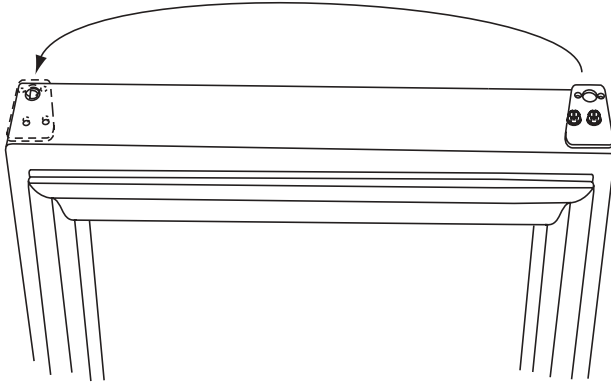

Figure 9

5. Remove existing bottom hinge (3 screws) and remount on opposite side TOP. Remove top hinge screw pin.
6. With bottom of door facing up, remove pivot plate and bushings (2 screws), flip over, and remount on opposite side of door (see Figure 10).



UL319a

**Figure 10**

7. Holding door upright with top of door tilted forward, place hole of door pivot plate on bottom hinge screw pin (see Figure 11). Be sure that the bosses on the closers align with holes in hinge and hinge plate.
8. Tilt top of door into position in top hinge and install top hinge screw pin.
9. Install plastic screw plugs removed in Step 2 in existing hinge holes (3 each, top and bottom).

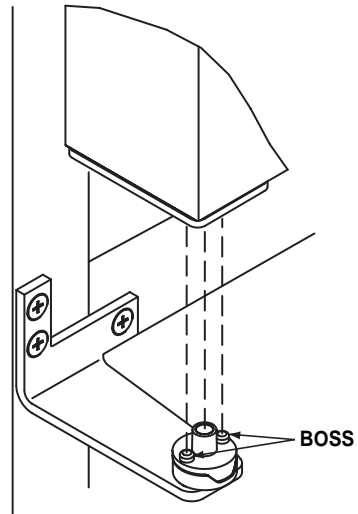

CLRC008

**Figure 11**

## DOOR ADJUSTMENT

Your Wine Captain doors were aligned at the factory before shipment. Occasional re-adjustment may be necessary. The following procedure will correct for up to 1/4" alignment.

### IMPORTANT

The door should never be flush with the top of the cabinet. Even when level, the top edge of the door will be 1/8" below the top of the cabinet (see Figure 12).

#### TO ADJUST DOOR:

1. Compare the top edge of the door (opposite the hinges) to the top edge of the cabinet and note the type (up or down) of adjustment needed.

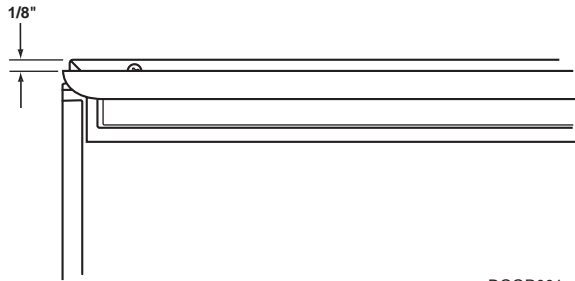

DOOR001a

Figure 12

2. Remove the top hinge pivot pin with a 7/64" hex wrench (see Figure 13) and lift door off bottom hinge pin. Be careful not to lose door closer inserts (see Figure 15).

3. With door upside-down, inspect the bottom hinge plate mounting holes.

- a. If your plate has slotted mounting holes, loosen but do not remove the two hinge plate screws.
- b. If your plate does not have slotted mounting holes, remove the old plate and install the new plate with the notch to the inside of the door (see Figure 14).

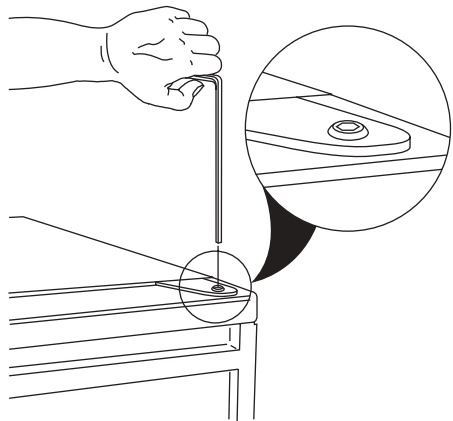

UL310

Figure 13

- If door edge opposite the hinges needs to move up, move plate toward outside of door. If door edge needs to move down, move plate toward inside of door (see Figure 14). Repeat until top edge of door is parallel with top of cabinet and tighten screws securely.

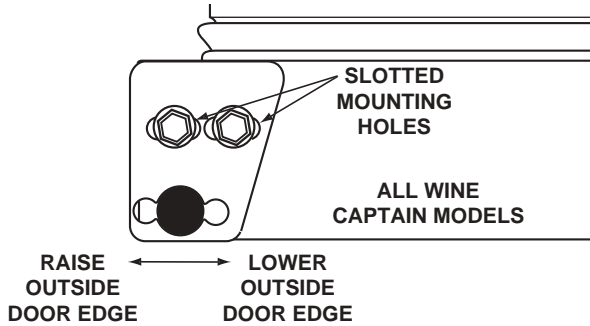

DOOR003a

**Figure 14**

- After adjustment is complete, remove the door closers from the bottom hinge, clean thoroughly and apply petroleum jelly to the mating surfaces of the closers (see Figure 15). Be sure that bosses on closers align with holes in hinge and hinge plate. Mount door and install top hinge pivot pin.

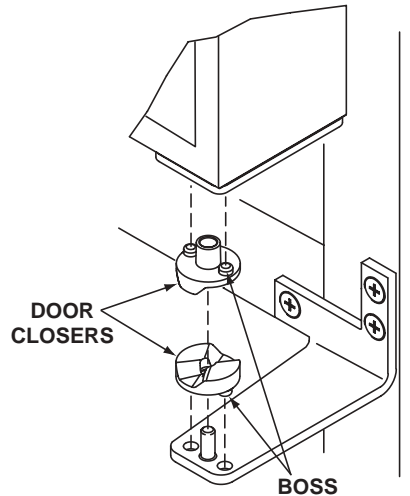

UL312

**Figure 15**

## BUILT-IN INSTALLATION

Your U-Line product has been designed for either free-standing or built-in installation. When built-in, your U-Line product does not require additional air space for top, sides, or rear. However, the front grille must NOT be obstructed.

### NOTE

To ease unit installation and removal, it is recommended that the cabinet rough opening dimensions be increased by at least 1/4" over the dimensions given for your unit.

### Unit Dimensions

Model	Width	Height	Depth*
2015 WC	14-15/16"	34-1/8"	24"
2075 WC	23-15/16"	34-1/8"	24"

## OPERATION

### THE RIGHT TEMPERATURE FOR WINE

Wine Captain models have a unique, triple temperature zone permitting storage of your finest wines at approximately 60°F (15°C in the top portion of the cabinet for reds, 50-55°F (10-12°C) in the middle for whites and 45°F (7°C) on the bottom for sparkling wines). Temperatures noted are product temperatures and not air temperatures.

### PROPER STORAGE

Model 2075WC will accommodate 48 bottles (750 ML size). Model 2015WC will accommodate 24 bottles (750 ML size). Specially designed wine racks allow for proper horizontal storage of the wine. The cork remains moist, which keeps air from entering the bottle.

## CONTROL SETTINGS

Your Wine Captain is shipped in the ON position, however, you may turn it ON or OFF using the control knob located in the center of the grille. Turn the control knob clockwise for ON, counterclockwise for OFF. To turn the unit OFF, rotate the control knob counterclockwise all the way toward warmer until it stops (until “click” is heard). The ON/OFF switch located to the right of the control knob is used to turn the inside light on and off (see Figure 16).

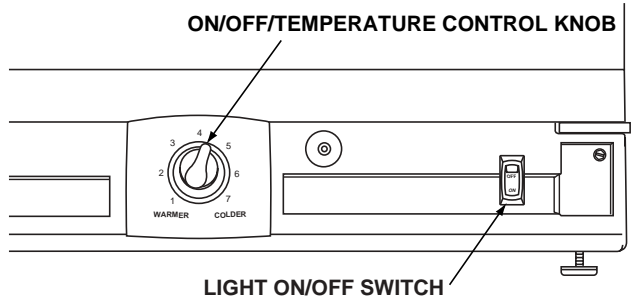

UL316A

Figure 16

## LIGHT SWITCH AND BULB

Your Wine Captain® model has an interior light that is illuminated when the door is opened. If you wish to display your wines for those “special occasions” while the door is closed, just depress the switch located to the right of the control dial on the grille to the ON position.

Please note when the light is on for an extended period of time it will increase the cabinet temperature, especially at the top.

## INITIAL START-UP

Wine Captain® models are designed to provide different temperature zones within the cabinet so different types of wine may be maintained at varying temperatures. The coolest temperature is at the bottom, and the warmest is at the top of the cabinet.

## ADJUSTING THE TEMPERATURE CONTROL

### CHECKING TEMPERATURE

To accurately check the temperature, insert an accurate thermometer into a plastic (non-breakable) bottle, partially filled with water. Tighten the bottle cap securely (see Figure 17).

Place the bottle in the desired area for 24 hours. Refrain from opening the unit during the testing period. After 24 hours, check the temperature of the water. Adjust the control knob if necessary and retest.

Your Wine Captain® is preset for a mid-point setting (4-1/2) in order to achieve the recommended temperature range when installed in a 72°F ambient room temperature. To achieve a warmer setting turn the control counterclockwise (lower number) and clockwise (higher number) for a cooler temperature (see Figure 18).

Factors which affect the internal temperatures of the cabinet include:

1. Temperature setting.
2. Room temperature where installed.
3. Number of times the door is opened and closed.
4. Amount of time the internal light is illuminated. This affects primarily wines on the top racks.
5. Installation in direct sun light or near a heat source.

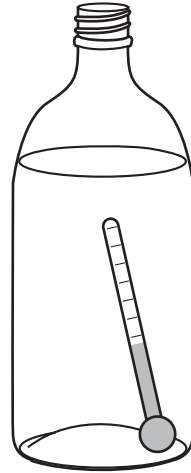

UL320

Figure 17

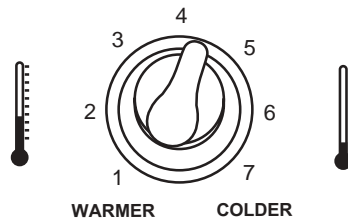

UL315

Figure 18

## DISPLAY RACK

The bottom rack in your Wine Captain® model is designed for storage as well as for display purposes. The 2015WC holds four bottles in the display rack and the 2075WC holds eight bottles.

## STOCKING RECOMMENDATIONS

The wine racks allow for the proper horizontal storage of wine. The bottles are properly positioned so that the wine remains in contact with the cork to assure that the cork does not become dry. Use the procedure listed below to stock your Wine Captain® model. White and sparkling wines should be maintained on the bottom to middle racks and red wine on the top racks.

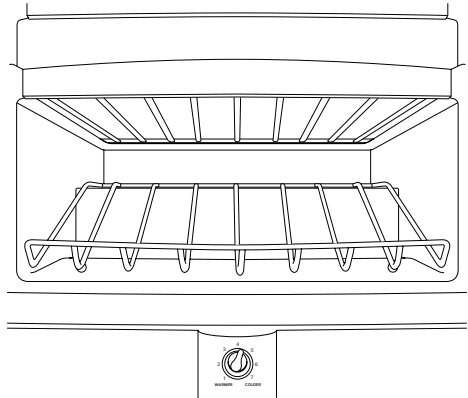

ULWC001

Figure 19

## CAUTION

The Anti-tip brackets **MUST** be installed before you begin loading your Wine Captain®.

Your Wine Captain®, models 2015WC and 2075WC, should be stocked beginning with the bottom display rack, at the back and work forward. Stagger the bottles as shown in Figure 20. Subsequent racks should be stocked similarly, starting with the back of each rack (see Figure 21).

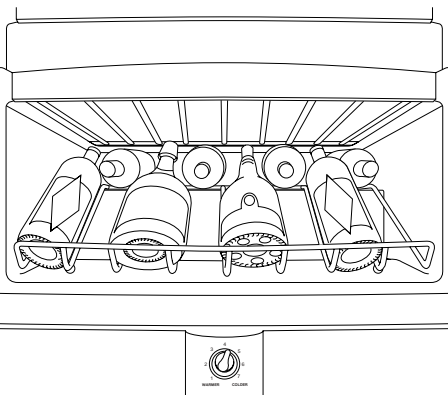

ULWC000

Figure 20

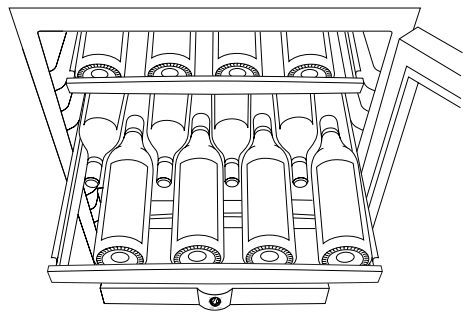

ULWC002

Figure 21

## MAINTENANCE

Periodic cleaning and proper maintenance will ensure efficiency, top performance, and long life. The maintenance intervals listed are based on normal conditions. You may want to shorten the intervals if you have pets or other special considerations.

### **EXTERIOR CLEANING — AS REQUIRED**

The door, grille and cabinet may be cleaned with a mild detergent and warm water solution. Do not use solvent based or abrasive cleaners. Use a soft sponge and rinse with clean water. Wipe with a soft, clean towel to prevent water spotting.

#### **Stainless Steel Models**

- Stainless steel models may discolor when exposed to chlorine gas, pool chemicals, salt water or cleaners with bleach.
- Keep your stainless unit looking new by cleaning with a high quality, all-in-one stainless steel cleaner/polish on a monthly basis. For best results use Claire Stainless Steel Polish and Cleaner, which can be purchased from U-Line Corporation. (Part number 173348/\$7.99 plus shipping and handling.) Frequent cleaning will remove surface contamination that could lead to rust. Some installations will require cleaning on a weekly basis.
- **DO NOT CLEAN WITH STEEL WOOL PADS.**
- **DO NOT USE CLEANERS THAT ARE NOT SPECIFICALLY INTENDED FOR STAINLESS STEEL (this includes glass, tile and counter cleansers).**
- If any surface discolors or rusting appears, clean it quickly with Bon-Ami or Barkeepers Friend Cleanser and a non-abrasive cloth. Always clean in the direction of the grain. Always finish this process with Claire Stainless Steel Polish and Cleaner to prevent further problems.
- **USE OF ABRASIVE PADS SUCH AS SCOTCHBRITE WILL CAUSE THE GRAINING IN THE STAINLESS TO BECOME BLURRED.**
- Rust that is allowed to linger can penetrate into the surface of the stainless steel and become impossible to remove.

## CAUTION

Stainless steel models exposed to chlorine gas and moisture, such as areas with spas or swimming pools, may have some discoloration of the stainless steel. Discoloration from chlorine gas is normal.

### INTERIOR CLEANING — AS REQUIRED

1. Disconnect power to the Wine Captain®.
2. Remove racks if desired, see **WINE RACK REMOVAL/INSTALLATION**.
3. Wipe down the interior with a solution of non-abrasive mild detergent and warm water.
4. Rinse with clear water.
5. Reconnect power to the unit.

### CONDENSER CLEANING - EVERY 3 MONTHS



## WARNING



Disconnect electric power to the unit before cleaning the condenser.

To remove and replace the grille for access to the condenser fins follow this procedure:

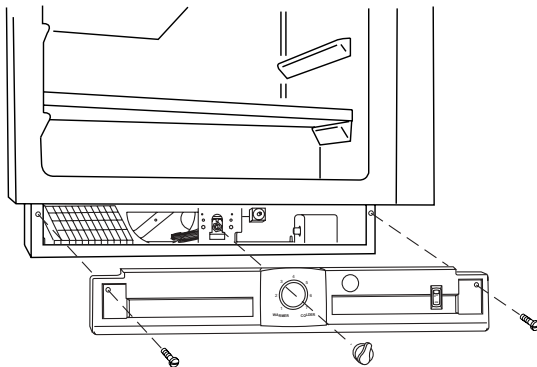

Figure 22

# User's Manual

---

---

1. Remove the control knob by grasping the knob and pulling straight off (see Figure 22).
2. Remove the screws at each end of the grille.
3. Remove the grille.



## WARNING

**DO NOT touch the condenser fins. The condenser fins are SHARP and can be easily damaged.**

4. Clean the condenser coil using a brush or vacuum cleaner. Do not touch.
5. Position the grille to align the screw holes with the cabinet.
6. Insert the grille screws and tighten being careful not to overtighten.
7. Install the control knob by aligning the flat of the control knob with the flat on the shaft. Push firmly.

## WINE RACK REMOVAL/INSTALLATION

To remove the wine racks for cleaning:

1. Grasp the end of the wine rack, sliding it out and up.
2. Clean wine rack with a damp rag.

To insert the wine racks:

1. Position the wine rack above the shelf channel where the rack is to be inserted. (See Figure 23.)
2. Slide the rack on the channel at an angle until the rack is in the channel.
3. Continue sliding until the rack is all the way into the Wine Captain®.

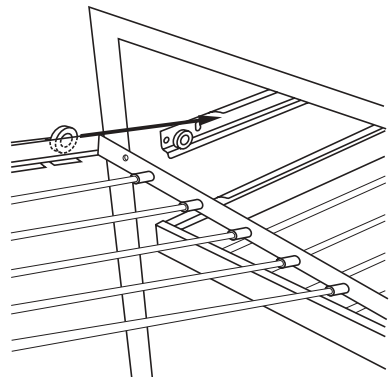

UL302

Figure 23

## BULB REPLACEMENT

To replace the light bulb in your Wine Captain®:

1. Remove the light housing cover by sliding the cover towards the tab, swinging the end opposite of the tab down and pulling down and away (see Figure 24).
2. Replace bulb with genuine U-Line replacement.
3. Replace the light housing cover by inserting the tab FIRST and pushing up the other end. You should hear a snap/click.

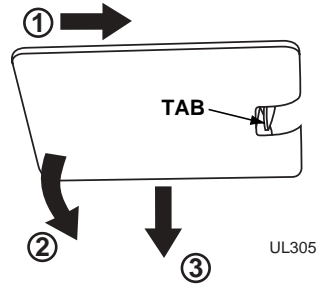

Figure 24

## TROUBLESHOOTING

### **BEFORE CALLING FOR SERVICE**

If the unit appears to be malfunctioning, read through NORMAL OPERATION first. If the problem persists, check the TROUBLESHOOTING GUIDE. Locate the problem in the guide and refer to the cause and its remedy before calling for service. The problem could be something very simple which can be solved without a service call.

Some remedies listed in the TROUBLESHOOTING GUIDE are very complex. Consulting or contracting a qualified service technician may be necessary.

### **IF SERVICE IS REQUIRED**

If the need for service arises, contact the dealer from whom the unit was purchased. State the Model Number and Serial Number and explain the problem. The Model and Serial Number plate is located inside unit at upper right hand corner.

If you do not know the name of the selling dealer or local service company, you can check online at [www.U-LineService.com](http://www.U-LineService.com) for a list of service companies.

### **REPLACEMENT PARTS**

Use only genuine U-Line replacement parts. Genuine U-Line parts are designed to work correctly with U-Line products and offer superior service life. The use of non-U-Line parts can damage the unit and may void the warranty. State the Model and Serial number and explain the problem. The Model and Serial number plate is located inside the unit at upper right hand corner.

# TROUBLESHOOTING GUIDE



## ELECTROCUTION HAZARD

**NEVER** attempt to repair or perform maintenance on the unit until the main electrical power has been disconnected.

### Troubleshooting — What to check when problems occur

<b>Problem</b>	<b>Possible Cause</b>	<b>Remedy</b>
Unit not cold enough.  Check temperatures (see introduction for specific temperatures)	Control set too warm	Turn control knob <b>CLOCKWISE</b> to set temperature colder. Allow 24 hours for temperature to stabilize.
	Light staying on	Check that light switch bracket contacts switch plunger.
	Airflow to front grille blocked	Airflow must not be obstructed to front grille. See <b>INSTALLATION</b>
	Dirty condenser coils	Clean condenser. See <b>MAINTENANCE</b>
	Door gasket not sealing properly	Adjust door gasket.
Unit too cold.  Check temperatures (see introduction for specific temperatures)	Control set too cold	Turn control knob <b>COUNTER-CLOCKWISE</b> to set temperature warmer. Allow 24 hours for temperature to stabilize.
No interior light	Loose or burned out bulb	Tighten or replace bulb. See <b>BULB REPLACEMENT</b> .
Light won't go out when door is closed	Light on/off switch is turned to <b>ON</b> .	Turn switch to <b>OFF</b> . See <b>LIGHT SWITCH AND BULB</b> .

# User's Manual

---

---





*P. O. Box 245040*

*Milwaukee, WI 53224-9540*

*Phone: 414.354.0300*

*Fax: 414.354.7905*

*[www.u-line.com](http://www.u-line.com)*